

The heritability of hedonic capacity and perceived stress: a twin study evaluation of candidate depressive phenotypes

R. Bogdan and D. A. Pizzagalli*

Department of Psychology, Harvard University, Cambridge, MA, USA

Background. Anhedonia and stress sensitivity have been identified as promising depressive phenotypes. Research suggests that stress-induced anhedonia is a possible mechanism underlying the association between stress and depression. The present proof-of-concept study assessed whether hedonic capacity and stress perception are heritable and whether their genetic and environmental contributions are shared.

Method. Twenty monozygotic (MZ) and 15 dizygotic (DZ) twin pairs completed a probabilistic reward task that provides an objective behavioral measure of hedonic capacity (reward responsiveness) and completed several questionnaires including the Perceived Stress Scale (PSS). Bivariate Cholesky models were used to investigate whether covariation between (1) depressive symptoms and hedonic capacity, (2) depressive symptoms and perceived stress, and (3) perceived stress and hedonic capacity resulted from shared or residual genetic and environmental factors.

Results. Additive genetic (A) and individual-specific environment (E) factors contributed to 46% and 54% of the variance in hedonic capacity, respectively. For perceived stress, 44% and 56% of the variance was accounted for by A and E factors, respectively. The genetic correlation between depression and hedonic capacity was moderate ($r_a=0.29$), whereas the correlation between depression and stress perception was large ($r_a=0.67$). Genetic and environmental correlations between hedonic capacity and stress perception were large ($r_a=0.72$ and $r_e=-0.43$).

Conclusions. The present study provides initial feasibility for using a twin approach to investigate genetic contributions of a laboratory-based anhedonic phenotype. Although these preliminary findings indicate that hedonic capacity and perceived stress are heritable, with substantial shared additive genetic contributions, replications in larger samples will be needed.

Received 28 November 2007; Revised 9 April 2008; Accepted 14 April 2008; First published online 28 May 2008

Key words: Depression, genetic, reward, stress, stress appraisal, twin.

Introduction

Current mental illness classification systems, such as the Diagnostic and Statistical Manual of Mental Disorders (DSM-IV; APA, 2000), take an atheoretical approach to the etiology and pathophysiology of mental illness by relying upon phenomenological descriptions of symptom clusters and clinical course as diagnostic criteria (Hyman, 2007). One issue stemming from these nosological systems is that they identify categorical illnesses that are inherently heterogeneous. As an illustration, the DSM-IV requires that five of nine symptoms (with at least one symptom being depressed mood or anhedonia) must be endorsed to meet criteria for major depressive disorder (MDD);

this produces 105 unique symptom combinations. Given that distinct disorder components are likely to be associated with different pathophysiologies, it is not surprising that this heterogeneity has hindered our ability to identify genetic, neurobiological and environmental factors contributing to depression (Hasler *et al.* 2004). To overcome these challenges, researchers have suggested focusing on narrowly defined and quantifiable phenotypes, which arguably represent a more direct expression of biological and environmental influences than the overall disorder (e.g. Meyer-Lindenberg & Weinberger, 2006).

Anhedonia, the loss of pleasure or lack of reactivity to pleasurable stimuli, is a promising depressive phenotype; it is a cardinal symptom of depression that has been associated with greater depression severity, poor treatment response, and reduced activity in reward-related brain regions (Kasch *et al.* 2002; Hasler *et al.* 2004; Keedwell *et al.* 2005). Despite theories suggesting that anhedonia is a genetically

* Address for correspondence: D. A. Pizzagalli, Ph.D., Department of Psychology, Harvard University, 1220 William James Hall, 33 Kirkland Street, Cambridge, MA 02138, USA.
(Email: dap@wjh.harvard.edu)

influenced vulnerability factor for depression (e.g. Meehl, 1975), few studies have investigated the heritability of hedonic capacity. Furthermore, the limited research available has relied exclusively on self-report measures tapping a broad range of hedonic processes. Growing evidence suggests, however, that hedonic capacity is not a monolithic phenomenon but can instead be parsed into distinct psychological, neural and neurochemical subcomponents (e.g. Berridge & Kringelbach, 2008). In light of these findings, it is perhaps not surprising that studies based on self-report assessments of anhedonia have yielded wide heritability estimates (from 27% to 82%; Dworkin & Saczynski, 1984; Berenbaum *et al.* 1990; Kendler *et al.* 1991; Heath *et al.* 1994; Hay *et al.* 2001; MacDonald *et al.* 2001; Ono *et al.* 2002; Linney *et al.* 2003; Keller *et al.* 2005). In the present study, we used a probabilistic reward task to objectively assess a fundamental aspect of hedonic capacity, reward responsiveness, which can be conceptualized as an individual's ability to modify behavior according to reinforcement history.

Increased stress sensitivity has been identified as a further promising depressive phenotype (Hasler *et al.* 2004). Animal research (e.g. Anisman & Matheson, 2005) supported by limited human findings (e.g. Bogdan & Pizzagalli, 2006) suggests that the depressogenic effects of stress may be partly attributable to stress-induced hedonic deficits. Surprisingly, with the exception of a recent study showing that the heritability of perceived stress ranges from 5% to 45% depending on self-report assessment (Federenko *et al.* 2006), little is known about the heritability of this important depressive phenotype.

The primary goals of the present study were to investigate (1) the feasibility of using a twin approach to assess the genetic contributions of a laboratory-based anhedonic phenotype that was recently shown to characterize MDD subjects (Pizzagalli *et al.* 2008*b*); (2) whether this objective measure of reward responsiveness is heritable; and (3) whether genetic and environmental influences are shared between reward responsiveness and perceived stress. A secondary goal was to replicate findings that perceived stress is heritable (Federenko *et al.* 2006). We hypothesized that both reward responsiveness and perceived stress would be moderately heritable and share genetic and environmental components.

Method

Participants

The final sample consisted of 20 monozygotic (MZ) (age 29.00 ± 10.90 years; 90% female; 95% Caucasian)

and 15 dizygotic (DZ) (age 33.73 ± 13.54 years; 87% female; 87% Caucasian) twin pairs who attended the 30th Annual Twins Days Festival in Twinsberg, Ohio[†]. Zygosity groups did not differ in age, education, gender, ethnicity, income, or behavioral task performance (p 's > 0.12). All participants reported normal vision and no current or past psychiatric disorder, neurological illness or learning disorder. Participants received US\$5 for their time and 'won' US\$5 during the probabilistic reward task. All participants provided informed written consent prior to participation. The Committee on the Use of Human Subjects at Harvard University approved the study.

Procedure

Participants completed the probabilistic reward task on a computer in a research booth on festival grounds. The following paper-and-pencil measures were collected: (1) demographic information; (2) two zygosity questionnaires (Kasriel & Eaves, 1976; Ooki *et al.* 1990); (3) the Mood and Anxiety Symptom Questionnaire (MASQ; Watson *et al.* 1995) to assess anxiety-specific symptoms (Anxious Arousal, AA), depression-specific symptoms (Anhedonic Depression, AD), and general distress (General Distress Anxious Symptoms, GDA; General Distress Depressive Symptoms, GDD); (4) the Beck Depression Inventory-II (BDI-II; Beck *et al.* 1996) to assess depressive symptomatology; and (5) the Perceived Stress Scale (PSS; Cohen *et al.* 1983) to assess subjective perception of life stress. In the present sample, Cronbach's α reliabilities for all questionnaires were excellent (0.83–0.94).

Probabilistic reward task

The reward task was adapted from Tripp & Alsop (1999) and has been described in detail and validated in multiple independent samples (e.g. Pizzagalli *et al.* 2005; Barr *et al.* 2006). In addition to standard measures of hit rate and reaction time (RT), this task allows for the computation of response bias, which reflects the participant's tendency to select one stimulus regardless of actual stimulus presentation. Unequal frequency of reward following correct identification of two stimuli produces a systematic preference (response bias) for the response paired more frequently with reward (Macmillan & Creelman, 2005). In the present study, response bias was used to assess how subjects modulated their behavior as a function of prior reinforcement history.

[†] The notes appear on p. 217.

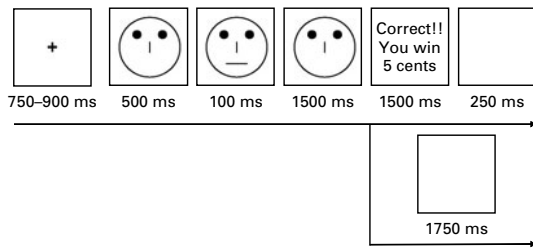

Fig. 1. Schematic representation of the task design and trial presentation.

Participants completed three blocks of 80 trials in which they decided whether a mouth was either long (11 mm) or short (10 mm) by making an appropriate response on a computer keyboard ('v' or 'm'; Fig. 1). Importantly, the small size difference between stimuli and the short exposure time made it difficult to ascertain which stimulus was presented. An asymmetric reward schedule between stimulus types was used to induce a response bias. Specifically, in each block, correct identification of one stimulus ('rich stimulus') was rewarded ('Correct!! You won 5 cents') three times more frequently (24 times) than the other ('lean stimulus'; 8 times). Key assignment and stimuli were counterbalanced across pairs. Participants were informed that their goal was to win as much money as possible and that not all correct responses would be rewarded.

Data reduction

A two-step procedure was used to identify outlier responses (see Bogdan & Pizzagalli, 2006). Next, hit rates [= (number of hits)/(number of hits + number of misses)] and RT scores were calculated for rich and lean stimuli separately. Response bias was computed as follows:

$$\log b = \frac{1}{2} \log \left(\frac{\text{Rich}_{\text{correct}} \times \text{Lean}_{\text{incorrect}}}{\text{Rich}_{\text{incorrect}} \times \text{Lean}_{\text{correct}}} \right).$$

Statistical analyses

Twin analyses

Pearson correlation analyses provided MZ and DZ twin pair correlations. Model fitting can be used to estimate the extent of additive genetic (A), dominant genetic (D), common environment (C), and non-shared environment/measurement error (E) contributions (Purcell, 2001; Rijdsdijk & Sham, 2002). The factor 'A' represents the sum of the effects of individual alleles at all loci, whereas 'D' captures interactions between alleles. 'C' represents environmental influences shared by family members, whereas 'E'

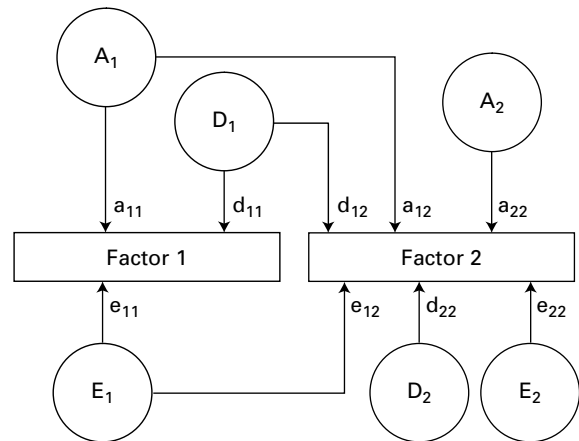

Fig. 2. Path diagram for the bivariate Cholesky decomposition ADE model. The 'A' and 'D' components are correlated with $r = 1.00$ between monozygotic (MZ) twins and 0.5 and 0.25 in dizygotic (DZ) twins respectively. Three independent bivariate models were run: Model 1: Factor 1 = general distress depressive symptoms (GDD), Factor 2 = block 3 response bias; Model 2: Factor 1 = GDD, Factor 2 = perceived stress; Model 3: Factor 1 = perceived stress, Factor 2 = block 3 response bias.

captures individual-specific environment influences (and measurement error). In the present study, an ADE model was chosen based on the observations that (1) correlations involving block 3 response bias and MASQ GDD were more than twice as large in MZ than DZ twins, and (2) an ADE model provided a better fit than an ACE model (findings available upon request).

As both hedonic capacity and perceived stress have been associated with depression severity (e.g. Kasch *et al.* 2002; Candrian *et al.* 2007), and stress diminishes reward responsiveness (e.g. Bogdan & Pizzagalli, 2006), three independent bivariate ADE Cholesky decomposition models were applied to evaluate shared and residual A, D and E contributions to depression, reward responsiveness (block 3 response bias) and perceived stress. The first Cholesky model specified three latent factors (A_1 , D_1 and E_1) with pathways influencing both depression (MASQ GDD; a_{11} , d_{11} and e_{11}) and reward responsiveness (a_{12} , d_{12} and e_{12}), in addition to three factors (A_2 , D_2 and E_2) accounting for residual influences specific to reward responsiveness (Fig. 2). The second and third model were identical to the first, with the exception that perceived stress replaced reward responsiveness and perceived stress replaced GDD respectively. These bivariate models yielded correlations between additive genetic (r_a), dominant genetic (r_d), and individual-specific environment factors (r_e) influencing the two phenotypes under investigation.

Full models were compared to nested submodels containing reduced parameters. Akaike's Information Criterion (AIC), which combines degrees of freedom with χ^2 goodness of fit, was used to evaluate model fit; the model with the lowest AIC value not significantly departing from the full model was chosen as the best-fitting model as it provides the best balance between parsimony and exploratory power. Model-fitting analyses were performed with Mx (Neale *et al.* 1999) following established procedures (e.g. Kendler *et al.* 2007; Orstavik *et al.* 2007).

Analyses focused on response bias in block 3 because this variable fully captures overall reward responsiveness after contingencies have been learned². The GDD scale of the MASQ was used as a measure of depression because this subscale, unlike the BDI-II scale, is relatively unrelated to anhedonic symptoms (Watson *et al.* 1995). This statistical non-overlap was important in light of prior findings linking decreased reward responsiveness to anhedonic symptoms (e.g. Pizzagalli *et al.* 2005).

Control analyses

An analysis of variance (ANOVA) with Block (1, 2, 3) was performed on response bias scores across all subjects. Stimulus Type (Rich, Lean) was added as a factor to hit rates and RT ANOVAs. *Post-hoc* Newman-Keuls tests evaluated significant ANOVA effects. Pearson correlations were calculated to investigate relationships between (1) response bias and (2) depressive/anxiety symptoms (MASQ and BDI) as well as perceived stress (PSS).

Results

Twin analyses

All MZ twin correlations were higher than corresponding DZ correlations (Table 1). Bivariate Cholesky ADE decomposition model-fitting results are shown in Table 2. The best-fitting model for GDD and reward responsiveness was model IV, which dropped all dominant genetic pathways (d_{11} , d_{12} , d_{22}) and the common individual-specific environmental pathway (e_{12}) from the model. This model estimated that additive genetic influences explained 46% [95% confidence interval (CI) 0.07–0.72] and 43% (95% CI 0.00–0.76) of the variance in reward responsiveness and GDD respectively, and individual-specific environment/measurement error accounted for the remainder. According to this model, reward responsiveness and GDD are influenced by some of the same genes ($r_a=0.29$, 95% CI -0.28 to 1.00). Thus, the overall heritability estimate of reward responsiveness can be subdivided into a small portion that was

Table 1. Twin correlations for response bias and self-report measures

	MZ ($n=20$ pairs)	DZ ($n=15$ pairs)
Response bias		
Block 3	0.59***	-0.05
Block 3 – Block 1	0.05	-0.18
Self-report measures		
MASQ GDA	0.41*	0.04
MASQ AA	0.39*	-0.11
MASQ GDD	0.35	0.06
MASQ AD	0.68***	0.39
BDI-II Total	0.74***	0.09
BDI-II Anhedonia	0.36	0.01
BDI-II Melancholia	0.55**	0.26
PSS	0.35	0.27

MZ, Monozygotic; DZ, dizygotic; MASQ, Mood and Anxiety Symptom Questionnaire (Watson *et al.* 1995; GDA, General Distress Anxious Symptoms; GDD, General Distress Depressive Symptoms; AA, Anxious Arousal; AD, Anhedonic Depression); BDI-II, Beck Depression Inventory-II (Beck *et al.* 1996); BDI-II Anhedonia (Pizzagalli *et al.* 2005), sum of BDI items associated with anhedonic symptoms (item 4: loss of pleasure; item 12: loss of interest; item 15: loss of energy; item 21: loss of interest in sex); BDI-II Melancholia (Pizzagalli *et al.* 2005), sum of BDI items associated with melancholic symptoms (items 4, 12, 21; item 5: guilty feelings; item 11: agitation; item 6b: early morning awakening); PSS, Perceived Stress Scale (Cohen *et al.* 1983).

*** $p < 0.01$, ** $p < 0.05$, * $p < 0.10$.

attributable to genetic effects also acting on GDD (0.04) and also residual effects that were unique to reward responsiveness (0.42)³.

The best-fitting model for GDD and perceived stress was model III, which dropped all dominant genetic pathways (d_{11} , d_{12} , d_{22}). According to this model, genetic contributions accounted for 40% (95% CI 0.00–0.75) and 44% (95% CI 0.05–0.70) of the variance in GDD and perceived stress respectively; individual-specific environment/measurement error accounted for the remainder. The genetic correlation was estimated to be high ($r_a=0.67$) but the CI was wide (95% CI -1.00 to 1.00). The individual-specific environment correlation was moderate ($r_e=0.33$, 95% CI -0.10 to 0.66). Thus, the overall heritability estimate of perceived stress can be subdivided into a large portion that was attributable to genetic effects acting on GDD (0.20) and also a residual part that was unique to perceived stress (0.24). Similarly, the overall individual-specific environmental contribution can be subdivided into a small portion attributable to individual-specific environmental factors

Table 2. Bivariate model fitting for block 3 response bias and perceived stress

Model	Common pathways						Specific pathways			Model fit parameters						
	Factor 1			Factor 2			Factor 2			GDDR B		GDDPSS		PSSRB		
	a ₁₁	d ₁₁	e ₁₁	a ₁₂	d ₁₂	e ₁₂	a ₂₂	d ₂₂	e ₂₂	df	AIC	p	AIC	p	AIC	p
I	+	+	+	+	+	+	+	+	+	129	178.58		708.87		176.23	
II	+	+	+	+		+	+		+	131	175.92	0.51	705.25	0.83	173.44	0.55
III	+		+	+		+	+		+	132	175.06	0.48	703.61	0.86	171.44	0.75
IV	+		+	+			+		+	133	173.14	0.63	703.84	0.56	174.07	0.21
V	+		+			+	+		+	133	173.39	0.59	704.13	0.52	174.86	0.16
VI	+		+			+			+	134	176.37	0.17	704.60	0.33	179.27	0.02

a, Additive genetic factors; d, dominant genetic factors; e, non-shared environment/measurement error; df, degrees of freedom, +, included pathway; GDDR B, bivariate Cholesky model with general distress depression [Mood and Anxiety Symptom Questionnaire (MASQ) General Distress Depressive Symptoms (GDD)] (Factor 1) and block 3 response bias (Factor 2); GDDPSS, bivariate Cholesky model with MASQ GDD (Factor 1) and perceived stress (Factor 2); PSSRB, bivariate Cholesky with perceived stress (Factor 1) and block 3 response bias (Factor 2); AIC, Akaike’s Information Criterion.

The lowest AIC value determined the best model fit. Best-fitting models are in bold.

contributing to GDD (0.05) and unique contributions to stress perception (0.51).

The best-fitting model for perceived stress and reward responsiveness was model III. According to this model, additive genetic factors contributed to 45% (95% CI 0.12–0.70) and 48% (95% CI 0.14–0.73) of variance in stress perception and reward responsiveness respectively; the majority of this genetic variance was shared between perceived stress and reward responsiveness ($r_a = 0.72$, 95% CI 0.11–1.00) whereas individual-specific environment/measurement error factors were negatively correlated ($r_e = -0.43$, 95% CI -0.69 to -0.04 ; Fig. 3). Thus, the overall heritability estimate of reward responsiveness can be subdivided into a large portion that overlaps with genetic effects acting on stress perception (0.25) and also a residual component that was unique to reward responsiveness (0.23). Similarly, the overall individual-specific environmental contribution can be subdivided into a small portion attributable to factors contributing to perceived stress (0.10) and unique contributions to reward responsiveness (0.42).

Control analyses

Consistent with past research (e.g. Pizzagalli *et al.* 2005; Bogdan & Pizzagalli, 2006), analyses on response bias produced a main effect of Block [$F(2, 136) = 3.51$, $p < 0.05$, partial $\eta^2 = 0.05$] due to increases from block 1 (0.10 ± 0.18) to block 2 (0.14 ± 0.19) and block 3 (0.16 ± 0.18 ; Newman–Keuls all p 's < 0.04). Control analyses on hit rates and RT data confirmed these results; the rich hit rate increased over time and was greater than the lean hit rate in

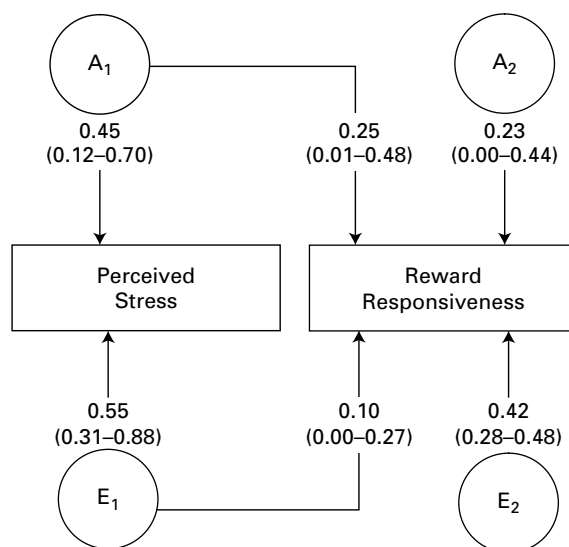

Fig. 3. The best-fitting bivariate Cholesky decomposition model for perceived stress and reward responsiveness. Numbers provided are percentage of variance.

each block and RT decreased over time, more so for the rich stimulus type (F 's > 3.50 , p 's < 0.05 ; all Newman–Keuls $p < 0.03$). Collectively, these findings suggest that the task elicited the intended effects; participants developed a behavioral preference towards the more frequently rewarded (rich) stimulus, as evident from the response bias, hit rate and RT findings. Contrary to previous studies (Pizzagalli *et al.* 2005; Bogdan & Pizzagalli, 2006), however, no significant correlations emerged between self-report data and response bias (all $|r| < 0.19$, all p 's > 0.12).

Discussion

The main goals of the present study were to (1) evaluate the feasibility of a twin approach to investigate genetic contributions to a laboratory-based anhedonic phenotype, (2) provide preliminary heritability estimates for reward responsiveness and perceived stress, and (3) assess the genetic and environmental correlation between perceived stress and reward responsiveness.

The present findings provide initial evidence that both reward responsiveness and perceived stress are heritable and influenced by individual-specific environmental factors. Consistent with previous literature assessing components of hedonic capacity (e.g. Loas, 1996), findings revealed that additive genetic factors and individual-specific environment/measurement error contributed to 46% and 54% of the variance in reward responsiveness respectively. Moreover, replicating prior findings (Federenko *et al.* 2006), heritability estimates suggested that additive genetic factors contributed to 44% of the variance in stress perception and individual-specific environment contributed to the remainder. Of note, the genetic correlation between GDD and reward responsiveness was modest ($r_a=0.29$). This finding is in line with conceptualizations suggesting that low positive affect and high negative affect are separate components of depression, with the former uniquely differentiating depression from anxiety and general negative affectivity being a non-specific factor linked to both disorders (Watson *et al.* 1995). More generally, this finding highlights the heterogeneity of depression and provides support for the endophenotypic research conceptualization (e.g. Hasler *et al.* 2004). In contrast to GDD and reward responsiveness, the genetic overlap between perceived stress and GDD was large ($r_a=0.67$); this overlap may be the result of robust associations between neuroticism, stress perception and depression (e.g. Federenko *et al.* 2006; Kendler *et al.* 2006).

Importantly, this study suggests substantive overlap between genetic and individual-specific environmental factors influencing stress perception and reward responsiveness. Thus, genes that enhance perceived stress also increase reward responsiveness ($r_a=0.72$); conversely, individual-specific environmental factors that enhance perceived stress decrease reward responsiveness ($r_e=-0.43$). Genetic overlap between stress perception and reward responsiveness is intriguing, particularly when considering a large body of animal and human work emphasizing links between increased stress sensitivity and vulnerability to addiction, including evidence that stress can enhance the rewarding properties of addictive drugs

(Kreek *et al.* 2005; Hyman *et al.* 2006). The negative correlations between environmental factors influencing perceived stress and reward responsiveness, however, raise the possibility that life stressors increasing stress perception might have deleterious consequences on the ability to modulate behavior as a function of reinforcers. Although speculative, this interpretation is consistent with prior findings of (1) a negative relationship between perceived stress and reward responsiveness (Pizzagalli *et al.* 2007) and (2) increased anhedonia when facing laboratory (Bogdan & Pizzagalli, 2006) and naturalistic (Berenbaum & Connelly, 1993) stressors. The positive genetic correlation and negative environment correlation between stress perception and reward responsiveness may account for the lack of a phenotypic correlation in the present study.

The limitations of this study warrant attention. First, although comparable to some prior twin studies (e.g. Berenbaum *et al.* 1990; Kendler *et al.* 1991; Matthews *et al.* 2007), the small sample size limited our statistical power; this is evidenced by large 95% CIs. Second, data were collected outside controlled laboratory settings, which may have contributed to measurement error. However, MZ and DZ correlations were similar to those reported from other studies with larger samples (e.g. Hay *et al.* 2001; Federenko *et al.* 2006), and the general pattern of behavioral performance was comparable to prior independent samples tested with the same reward task in the laboratory⁴. Unlike prior studies using this paradigm, however, no significant correlations emerged between the behavioral task and depressive measures, highlighting an important limitation of this study.

Despite these limitations, this is the first twin study, to our knowledge, that assesses: (1) hedonic capacity with an objective behavioral measure, and (2) genetic and environmental correlations between general depression, reward responsiveness and perceived stress. The findings of this study extend prior research using this probabilistic reward task in which reduced reward responsiveness has been associated with (1) elevated depressive (particularly anhedonic) symptoms (Pizzagalli *et al.* 2005) and a clinical diagnosis of depression (Pizzagalli *et al.* 2008b); (2) acute laboratory-induced stress (Bogdan & Pizzagalli, 2006) and elevated perceived stress (Pizzagalli *et al.* 2007); and (3) pharmacologically induced reduction of dopaminergic transmission (Pizzagalli *et al.* 2008a). Collectively, these findings indicate that laboratory-based assessments of quantifiable aspects of depressive phenotypes might provide a powerful tool for parsing the heterogeneity characteristic of this complex and debilitating disease. In addition to replicating the present findings, molecular genetic

approaches will be required to test the potential contributions of various candidate genes to hedonic capacity (e.g. Noble, 2003; Bogdan *et al.* 2006) and perceived stress (e.g. Otte *et al.* 2007), which promise to provide crucial insights into the etiology of depression.

Acknowledgments

This study was supported by a Ditmars Research Fund and Sigma-Xi Grants-in-Aid-of-Research grant to R.B. and NIMH grant R01 MH68376 to D.A.P. R.B. was a Sackler Scholar in Psychopathology and was supported by an NIMH NRSA predoctoral training grant R90 DA023427-01 during the preparation of this manuscript. We thank Manuel Ferreira, Mei-Hua Hall and Shaun Purcell for statistical consultation. We are also grateful for the invaluable resources housed at the Mx scripts library (www.psy.vu.nl/mxbib/). Lastly, we thank the annual Twins Days festival organizers for facilitating the present project.

Notes

- ¹ Sixteen pairs were excluded from analyses due to performance below chance level ($n=4$), unclear zygosity ($n=3$), incomplete reinforcement exposure ($n=1$), task non-compliance ($n=1$), pregnancy ($n=1$), outlier status ($n=1$) or the use of psychotropic medications ($n=5$).
- ² Structural equation modeling was not performed on overall reward learning (i.e. block 3 response bias – block 1 response bias) because MZ and DZ correlations for this variable were not significant.
- ³ Shared genetic contributions to reward responsiveness (0.04) were calculated as $[\sqrt{(0.46) \times 0.29}]^2$, where 0.46 is the additive genetic influences to reward responsiveness and 0.29 is the genetic correlation (r_a) between GDD and reward responsiveness. Residual genetic contributions (0.42) were calculated as $0.46 - 0.04$.
- ⁴ To evaluate the psychometric properties of the present signal detection task, we compared the current data to data collapsed across three independent studies that were collected in the laboratory setting (Pizzagalli *et al.* 2005, 2007, 2008b). The results suggest no significant differences: Study, $F(1, 241) = 1.83$, $p > 0.17$; Study \times Block, $F(2, 482) = 0.09$, $p > 0.90$. Together with the Cronbach's α reliability estimates for the questionnaires, these findings suggest that the subjective and objective data collected in this study had satisfactory psychometric properties.

Declaration of Interest

Dr Pizzagalli has received research support from GlaxoSmithKline and Merck & Co., Inc. for research unrelated to the present study.

References

- Anisman H, Matheson K (2005). Stress, depression, and anhedonia: caveats concerning animal models. *Neuroscience and Biobehavioral Reviews* **29**, 525–546.
- APA (2000). *Diagnostic and Statistical Manual of Mental Disorders*, 4th edn, text revision (DSM-IV-TR). American Psychiatric Association: Washington, DC.
- Barr RS, Pizzagalli DA, Culhane MA, Goff DC, Evins AE (2006). A single dose of nicotine enhances reward responsiveness in non-smokers: implications for development of dependence. *Biological Psychiatry*. Published online: 30 October 2006. doi: 10.1016/j.biopsych.2007.09.015.
- Beck AT, Steer RA, Brown GK (1996). *Beck Depression Inventory Manual*, 2nd edn. The Psychological Corporation: San Antonio, TX.
- Berenbaum H, Connelly J (1993). The effect of stress on hedonic capacity. *Journal of Abnormal Psychology* **102**, 474–481.
- Berenbaum H, Oltmanns TF, Gottesman II (1990). Hedonic capacity in schizophrenics and their twins. *Psychological Medicine* **20**, 367–374.
- Berridge KC, Kringelbach ML (2008). Affective neuroscience of pleasure: reward in humans and animals. *Psychopharmacology*. Published online: 3 March 2008. doi:10.1007/s00213-008-1099-6.
- Bogdan R, Perlis RH, Pizzagalli DA (2006). The effects of 5-HTT genotype and stress on hedonic capacity. *Psychophysiology* **43**, S25.
- Bogdan R, Pizzagalli DA (2006). Acute stress reduces hedonic capacity: implications for depression. *Biological Psychiatry* **60**, 1147–1154.
- Candrian M, Farabaugh A, Pizzagalli DA, Baer L, Fava M (2007). Perceived stress and cognitive vulnerability mediate the effects of personality disorder comorbidity on treatment outcome in major depressive disorder. *Journal of Nervous and Mental Disease* **195**, 729–737.
- Cohen S, Kamarck T, Mermelstein R (1983). A global measure of perceived stress. *Journal of Health and Social Behavior* **24**, 385–396.
- Dworkin RH, Saczynski K (1984). Individual differences in hedonic capacity. *Journal of Personality Assessment* **48**, 620–626.
- Federenko IS, Schlotz W, Kirschbaum C, Bartels M, Hellhammer DH, Wust S (2006). The heritability of perceived stress. *Psychological Medicine* **36**, 375–385.
- Hasler G, Drevets WC, Manji HK, Charney DS (2004). Discovering endophenotypes for major depression. *Neuropsychopharmacology* **29**, 1765–1781.
- Hay DA, Martin NG, Foley D, Treloar SA, Kirk KM, Heath AC (2001). Phenotypic and genetic analyses of a short measure of psychosis-proneness in a large-scale Australian twin study. *Twin Research* **4**, 30–40.
- Heath AC, Cloninger CR, Martin NG (1994). Testing a model for the genetic structure of personality: a comparison of the personality systems of Cloninger and Eysenck. *Journal of Personality and Social Psychology* **66**, 762–775.

- Hyman SE** (2007). Can neuroscience be integrated into the DSM-V? *Nature Reviews Neuroscience* **8**, 725–732.
- Hyman SE, Malenka RC, Nestler EJ** (2006). Neural mechanisms of addiction: the role of reward-related learning and memory. *Annual Review of Neuroscience* **29**, 565–598.
- Kasch KL, Rottenberg J, Arnow BA, Gotlib IH** (2002). Behavioral activation and inhibition systems and the severity and course of depression. *Journal of Abnormal Psychology* **111**, 589–597.
- Kasriel J, Eaves L** (1976). The zygosity of twins: further evidence on the agreement between diagnosis by blood groups and written questionnaires. *Journal of Biological Science* **8**, 263–266.
- Keedwell PA, Andrew C, Williams SC, Brammer MJ, Phillips ML** (2005). The neural correlates of anhedonia in major depressive disorder. *Biological Psychiatry* **58**, 843–853.
- Keller MC, Coventry WL, Heath AC, Martin NG** (2005). Widespread evidence for non-additive genetic variation in Cloninger's and Eysenck's personality dimensions using a twin plus sibling design. *Behavior Genetics* **35**, 707–721.
- Kendler KS, Gardner CO, Gatz M, Pedersen NL** (2007). The sources of co-morbidity between major depression and generalized anxiety disorder in a Swedish national twin sample. *Psychological Medicine* **37**, 453–462.
- Kendler KS, Gatz M, Gardner CO, Pedersen NL** (2006). Personality and major depression: a Swedish longitudinal, population-based twin study. *Archives of General Psychiatry* **63**, 1113–1120.
- Kendler KS, Ochs AL, Gorman AM, Hewitt JK, Ross DE, Mirsky AF** (1991). The structure of schizotypy: a pilot multitrait twin study. *Psychiatry Research* **36**, 19–36.
- Kreek MJ, Nielsen DA, Butelman ER, LaForge KS** (2005). Genetic influences on impulsivity, risk taking, stress responsivity and vulnerability to drug abuse and addiction. *Nature Neuroscience* **8**, 1450–1457.
- Linney YM, Murray RM, Peters ER, MacDonald AM, Rijdsdijk F, Sham PC** (2003). A quantitative genetic analysis of schizotypal personality traits. *Psychological Medicine* **33**, 803–816.
- Loas G** (1996). Vulnerability to depression: a model centered on anhedonia. *Journal of Affective Disorders* **41**, 39–53.
- MacDonald AW III, Pogue-Geile MF, Debski TT, Manuck S** (2001). Genetic and environmental influences on schizotypy: a community-based twin study. *Schizophrenia Bulletin* **27**, 47–58.
- Macmillan NA, Creelman CD** (2005). *Detection Theory: A User's Guide*, 2nd edn. Lawrence Erlbaum: Mahwah, NJ.
- Matthews SC, Simmons AN, Strigo I, Jang K, Stein MB, Paulus MP** (2007). Heritability of anterior cingulate response to conflict: an fMRI study in female twins. *NeuroImage* **38**, 223–227.
- Meehl PE** (1975). Hedonic capacity: some conjectures. *Bulletin of the Menninger Clinic* **39**, 295–307.
- Meyer-Lindenberg A, Weinberger DR** (2006). Intermediate phenotypes and genetic mechanisms of psychiatric disorders. *Nature Reviews Neuroscience* **7**, 818–827.
- Neale MC, Boker SM, Xie G, Maes HH** (1999). *Mx: Statistical Modeling*. Department of Psychiatry, Box 126 MCV: Richmond, VA 23298.
- Noble EP** (2003). D2 dopamine receptor gene in psychiatric and neurologic disorders and its phenotypes. *American Journal of Medical Genetics. Part B, Neuropsychiatric Genetics* **116**, 103–125.
- Ono Y, Ando J, Onoda N, Yoshimura K, Momose T, Hirano M, Kanba S** (2002). Dimensions of temperament as vulnerability factors in depression. *Molecular Psychiatry* **7**, 948–953.
- Ooki S, Yamada K, Asaka A, Hayakawa K** (1990). Zygosity diagnosis of twins by questionnaire. *Acta Geneticae Medicae et Gemellologiae* **39**, 109–115.
- Orstavik RE, Kendler KS, Czajkowski N, Tambs K, Reichborn-Kjennerud T** (2007). The relationship between depressive personality disorder and major depressive disorder: a population-based twin study. *American Journal of Psychiatry* **164**, 1866–1872.
- Otte C, McCaffery J, Ali S, Whooley MA** (2007). Association of a serotonin transporter polymorphism (5-HTTLPR) with depression, perceived stress, and norepinephrine in patients with coronary disease: the Heart and Soul Study. *American Journal of Psychiatry*, **164**, 1379–1384.
- Pizzagalli DA, Bogdan R, Ratner KG, Jahn AL** (2007). Increased perceived stress is associated with blunted hedonic capacity: potential implications for depression research. *Behaviour Research and Therapy* **45**, 2742–2753.
- Pizzagalli DA, Evins AE, Schetter Cowman E, Frank MJ, Pajtas PE, Santesso DL, Culhane M** (2008a). Single dose of a dopamine agonist impairs reinforcement learning in humans: behavioral evidence from a laboratory-based measure of reward responsiveness. *Psychopharmacology* **196**, 221–232.
- Pizzagalli DA, Iosifescu D, Hallett LA, Ratner KG, Fava M** (2008b). Reduced hedonic capacity in major depressive disorder: evidence from a probabilistic reward task. *Journal of Psychiatric Research*. Published online: 21 April 2008. doi:10.1016/j.jpsychires.2008.03.001.
- Pizzagalli DA, Jahn AL, O'Shea JP** (2005). Toward an objective characterization of an anhedonic phenotype: a signal detection approach. *Biological Psychiatry* **57**, 319–327.
- Purcell S** (2001). Appendix: statistical methods. In *Behavioral Genetics*, 4th edn (ed. R. Plomin, J. C. DeFries, G. E. McClearn and P. McGuffin), pp. 327–371. Worth Publishers: New York.
- Rijdsdijk FV, Sham PC** (2002). Analytic approaches to twin data using structural equation models. *Briefings in Bioinformatics* **3**, 119–133.
- Tripp G, Alsop B** (1999). Sensitivity to reward frequency in boys and with attention deficit hyperactivity disorder. *Journal of Clinical Child Psychology* **28**, 366–375.
- Watson D, Weber K, Assenheimer JS, Clark LA, Strauss ME, McCormick RA** (1995). Testing a tripartite model: I. Evaluating the convergent and discriminant validity of anxiety and depression symptom scales. *Journal of Abnormal Psychology* **104**, 3–14.